

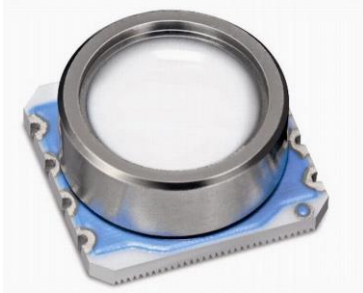

## WF5803 Miniature Variometer Module



- High resolution module
- Integrated digital pressure sensor (24 bit  $\Delta \Sigma$  ADC)
- Supply voltage 1.8 to 3.6 V
- Operating range 10 to 1300mbar, -40 to +85 ° C
- High-speed I<sup>2</sup>C interface
- Hermetically sealable for outdoor devices
- RoHS compatible

### DESCRIPTION

The WF5803 is a high resolution altimeter sensors with I<sup>2</sup>C bus interface. It is optimized for altimeters and variometers with an altitude resolution of 10 cm. The sensor module includes a high linearity pressure sensor and an ultra low power 24 bit  $\Delta \Sigma$  ADC with internal factory calibrated coefficients. It provides a precise digital 24 Bit pressure and temperature value and different operation modes that allow the user to optimize for conversion speed and current consumption. A high resolution temperature output allows the implementation of an altimeter/thermometer function without any additional sensor. The WF5803 can be interfaced to virtually any microcontroller. The communication protocol is simple, without the need of programming internal registers in the device. The gel protection and antimagnetic stainless steel cap allows the use in 100m water resistant altimeter/compass watches. This new sensor module is based on MEMS technology. The sensing principle employed leads to very low hysteresis and high stability of both pressure



# WF5803 Miniature Variometer Module

and temperature signal.

## APPLICATIONS

- Absolute pressure sensor systems
- Industrial automation
- Barometric pressure measurement
- Consumer appliance
- Variometers
- Dataloggers

## 1 Operation

### 1.1 Brief description

The WF5803 is designed to be connected directly to an external microcontroller of a mobile device via the I<sup>2</sup>C bus. The pressure and temperature data has to be compensated by the calibration data of the on-chip Non-Volatile Memory (NVM) which is individually factory calibrated for each device.

### 1.2 Function description

The WF5803 consists of a piezo-resistive micro-machined pressure sensor, an analog to digital converter and a control unit with Non-Volatile Memory (NVM) and a serial I<sup>2</sup>C interface. The WF5803 delivers the uncompensated values of the pressure and the temperature. The individual calibration data are stored in NVM. This is used to compensate sensitivity, offset, temperature dependence and other parameters of the sensor.



# WF5803 Miniature Variometer Module

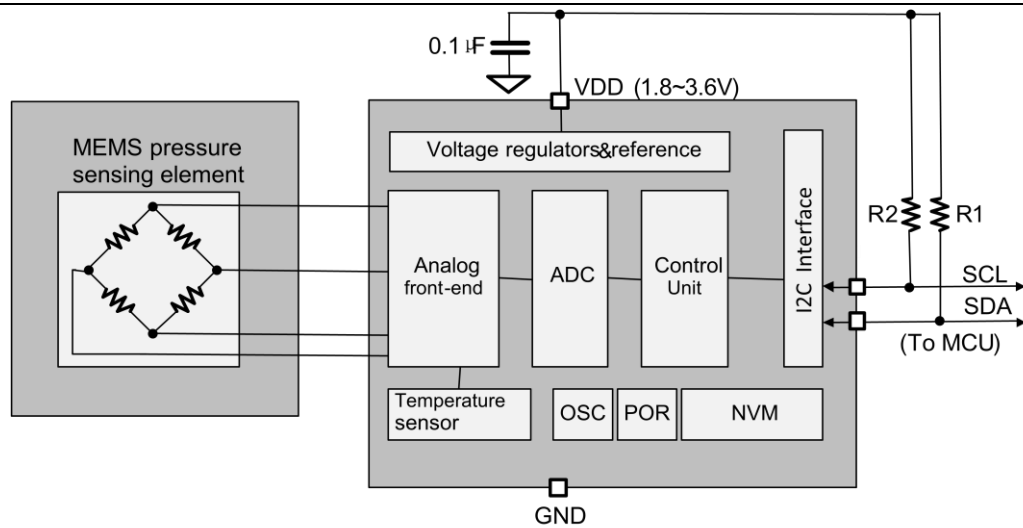

Figure 1 Block diagram of WF5803

## 1.3 Measurement of pressure and temperature

The microcontroller sends I<sup>2</sup>C command to start a pressure or temperature measurement. After converting time or checking status via the I<sup>2</sup>C, the result value (raw pressure data and raw temperature data) can be read via the I<sup>2</sup>C interface. For pressure and temperature calibration calculation in micro-controller, the calibration data in NVM has to be used. The constants can be read out from the WF5803's NVM via the I<sup>2</sup>C interface at software initialization.



# WF5803 Miniature Variometer Module

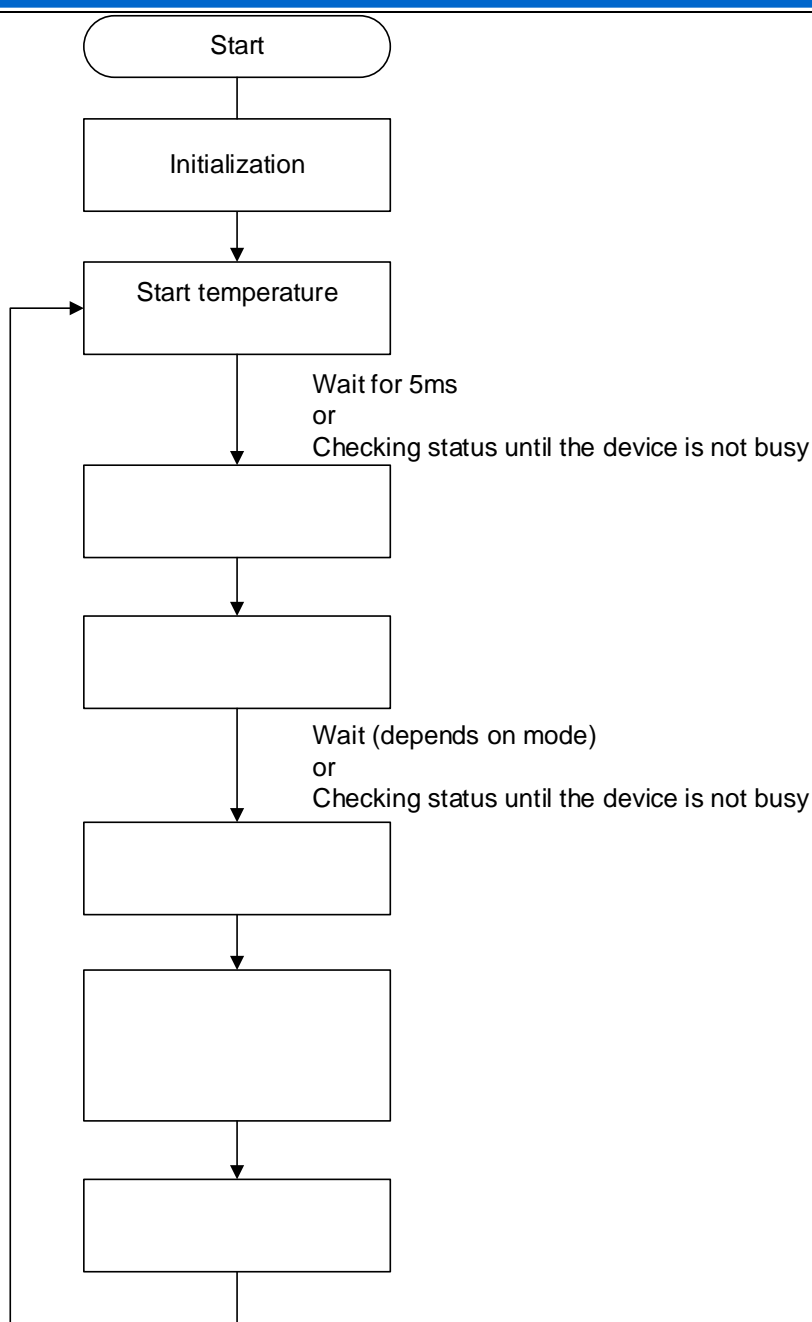

Figure 2 Measurement flow of WF5803

## 1.4 Timing of the measurements

The output data rate (ODR) of the measurements is controlled by the external micro-controller. A single measurement is performed according to the received I<sup>2</sup>C command. When the measurement is finished, the sensor returns to sleep mode and the measurement results can be obtained via I<sup>2</sup>C interface.



# WF5803 Miniature Variometer Module

The ODR can be increased to about 100 samples per second for dynamic measurement. For application with high ODR, constant  $t_{\text{delay}}$  is recommended as the self-heating of the pressure sensor and heat dissipation are in the balance if sampling rate is constant, which helps reducing the noise caused by irregular heat exchange between the sensor and the ambient environment. The recommended working timing diagram is shown in Figure 3.

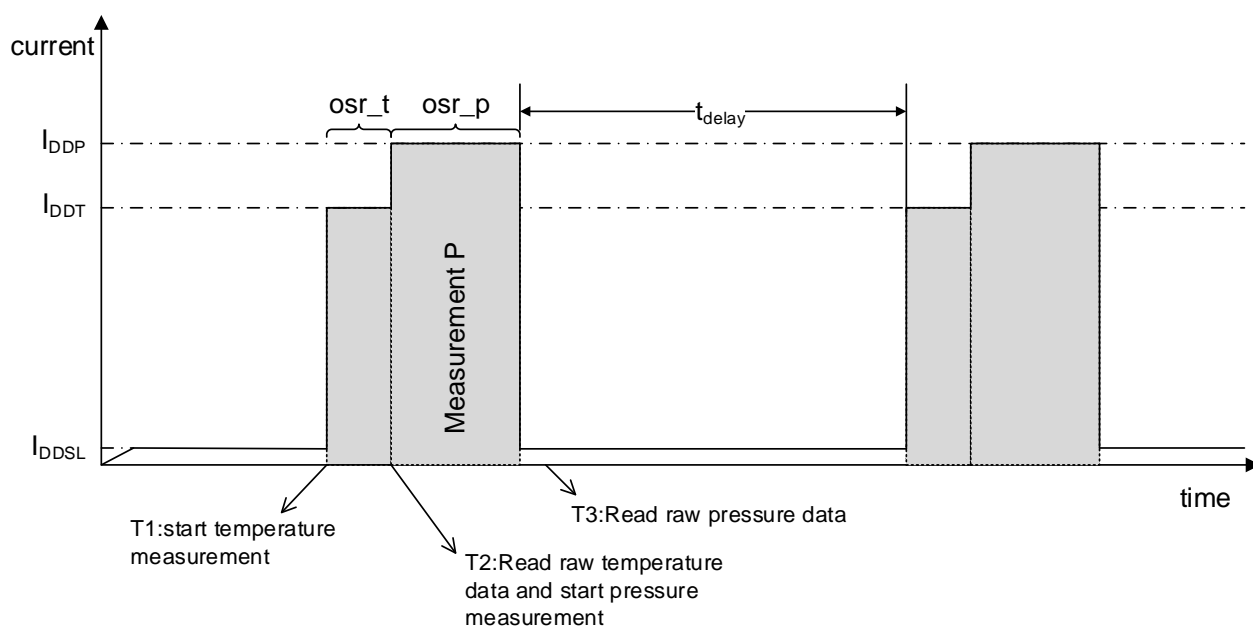

Figure 3 Recommended working timing diagram

For low power consideration, it is sufficient to measure the temperature only once per second and to use this value for all pressure measurements during the same period.

For applications which require low ODR or host-based synchronization, the  $t_{\text{delay}}$  can be set with any value larger than 0.5ms. The optimum compromise between power consumption, speed and resolution can be selected.

## 1.5 Current consumption

The current consumption depends on ODR and oversampling setting. The value given below are normalized to an ODR of 1Hz. The actual current consumption at a given ODR can be calculated by multiplying the value Table 1 with the given ODR.

Table 1 Current consumption



# WF5803 Miniature Variometer Module

Oversampling setting	Pressure oversampling	Temperature oversampling	I <sub>DD</sub> [μA] @ 1Hz	
			Typ	Max
Ultra low power	x1	x4	5.4	8.2
Low power	x2	x4	6.4	9.7
Standard resolution	x4	x4	9.0	13.7
High resolution	x8	x4	14.1	21.4
Ultra high resolution	x16	x4	24.6	37.4
<i>O2 Ultra high resolution*</i>	x32	x4	45.1	68.6
<i>O4 Ultra high resolution*</i>	x64	x4	86.4	131.3

\* "O2/4 Ultra high resolution" are not recommended for dynamic measurement with high ODR. Obvious self-heating phenomenon of the pressure sensor can be observed in these two settings. Ultra high resolution with IIR filter algorithm is recommended in this case.

## 1.6 Measurement time

The temperature and pressure measurement time depends on oversampling setting *osr\_t* and *osr\_p*. The following table shows the typical and maximum measurement time based on selected oversampling setting. The minimum achievable frequency is determined by the maximum measurement time.

Table 2 Measurement time

Oversampling setting (Single pressure or temperature)	Measurement time [ms]		Measurement rate [Hz]	
	Typ	Max	Typ	Min
x1	1.92	2.2	520.8	454.5
x2	3.5	4.1	285.7	243.9
x4	6.6	7.7	151.5	129.8
x8	12.7	14.7	78.7	68.0
x16	25.0	29.0	40.0	34.4
x32	49.6	57.6	20.1	17.3
x64	98.7	114.5	10.1	8.7

## 1.7 Software calculation flow

When the raw temperature data and raw pressure data are obtained by the MCU, the



## WF5803 Miniature Variometer Module

calculation is performed in the MCU for getting compensated temperature and pressure value in physical units. The simplified software calculation flow is shown in Figure 4.

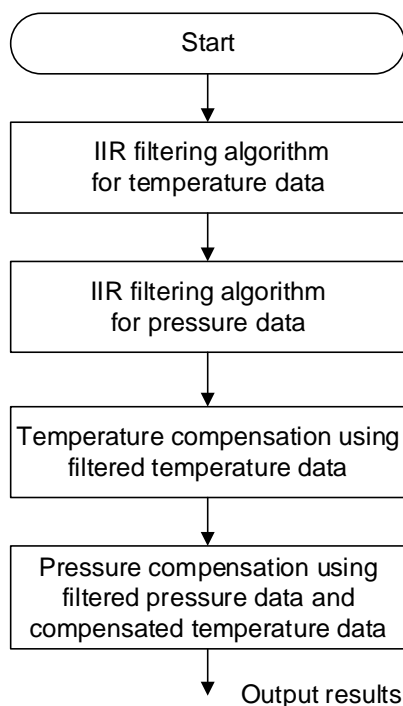

Figure 4 Software calculation flow

Note: Constant  $t_{\text{delay}}$  is preferred if IIR filtering algorithm is enabled. Please see Figure 3 for the definition of  $t_{\text{delay}}$ .

### 1.8 IIR filtering algorithm

For applications where a low noise level is critical, IIR filtering algorithm is strongly recommended if the lower bandwidth is acceptable. By applying IIR filtering algorithm before temperature and pressure compensation, the environmental pressure is subject to many short-term changes can be suppressed, such as slamming of a door or a window, or wind blowing into the sensor. IIR filtering algorithm effectively reduce the bandwidth of the output signals. The formula of the IIR filtering algorithm is as following:

$$\text{data\_filtered} = \frac{\text{data\_filtered\_previous} \cdot (\text{filter\_coefficient} - 1) + \text{raw\_data\_ADC}}{\text{filter\_coefficient}}$$

where  $\text{data\_filtered\_previous}$  is the data coming from the previous  $\text{data\_filtered}$ , and  $\text{raw\_data\_ADC}$  is the raw temperature data or raw pressure data coming from the ADC before IIR filtering. The  $\text{filter\_coefficient}$  is an integer range from 0 to 16. It controls the bandwidth of the sensor signal, please see Table 3.



# WF5803 Miniature Variometer Module

Table 3 Filtering algorithm setting

Filter_coefficient	Bandwidth (ODR is controlled by MCU)
1	Full (Filter off)
2	0.230 × ODR
4	0.092 × ODR
8	0.043 × ODR
16	0.021 × ODR

When IIR filtering algorithm is applied, it is better to keep delay time  $t_{delay}$  (see Figure 3) constant to obtain a fixed bandwidth. If temperature measurement is skipped, the corresponding raw\_data\_ADC will be kept unchanged. If filter\_coefficient is changed during the continuously measurements, an initial operation for IIR filtering algorithm will be performed.

In order to select optimal settings, the following use cases are suggested as shown in Table 4.

Table 4 Recommended filtering setting based on use cases

Use case	Over-sampling setting	osr_p	osr_t	IIR filter coeff.	IDD [μA]	ODR [Hz]	$t_{delay}$ [ms]	RMS Noise [cm]
Handheld device Low-power	Ultra high resolution	x16	x4	4	246	10.0	68	5.8
Handheld device dynamic	Standard resolution	x4	x4	16	630	70	0.5~1	2.5
Weather monitoring	low power	x2	x4	1 (off)	Off	1/60	60000	34.9
Elevator	Standard resolution	x4	x4	4	65.7	7.3	123	8
Drop detection	Low power	x2	x4	1 (off)	576	90	0.5~1	34.9
Indoor navigation	Ultra high resolution	x16	x4	16	647	26.3	6.4	1.6

## 1.9 Noise

Both pressure and temperature noise depend on the oversampling and IIR filter coefficient settings selected.



# WF5803 Miniature Variometer Module

Table 5 Noise in pressure

Typical RMS noise in pressure [Pa]					
Oversampling setting	Off	2	4	8	16
Ultra low power	6.0	2.9	1.7	1.0	0.7
Low power	4.2	2.5	1.3	0.7	0.4
Standard resolution	3.5	1.5	1.0	0.5	0.3
High resolution	2.8	1.3	0.9	0.4	0.2
Ultra high resolution	2.2	1.2	0.7	0.3	0.2
<i>O2 Ultra high resolution</i>	<i>2.0</i>	<i>1.1</i>	<i>0.5</i>	<i>0.3</i>	<i>0.2</i>
<i>O4 Ultra high resolution</i>	<i>TBD</i>	<i>TBD</i>	<i>TBD</i>	<i>0.3</i>	<i>0.2</i>

Table 6 Noise in temperature

Typical RMS noise in temperature [°C]	
Temperature oversampling	IIR filter off
oversampling x4	0.007
oversampling x8	0.006
oversampling x16	0.005
oversampling x32	0.004

## 1.10 Output compensation

The WF5803 output consists of the ADC output values include raw temperature and pressure data. Due to different characteristic of each sensing element, the actual pressure and temperature must be calculated using a set of calibration coefficients. These coefficients are individually factory calibrated and stored in the NVM. The NVM is organized with 16-bit data type.

### 1.10.1 Calibration coefficients

The NVM contains 11 calibration coefficients in total. Calibration coefficients are named co\_t1~co\_t3 for temperature compensation related values and co\_p1~co\_p8 for pressure compensation related values. The mapping is shown in Table 7.



# WF5803 Miniature Variometer Module

Table 7 Calibration coefficients storage in NVM

Addr.	Bit	Calibration coefficients	Addr.	Bit	Calibration coefficients
0x03	15	co_p8[16]	0x08	15:0	co_p5[15:0]
	14	reserved	0x09	15:0	co_p7[15:0]
	13:12	co_p3[25:24]	0x0A	15:0	co_p6[15:0]
	11:10	co_p6[25:24]	0x0B	15:0	co_p3[15:0]
	9:8	co_p7[25:24]	0x0C	15:0	co_t2[15:0]
	7:6	co_p5[25:24]	0x0D	15:0	co_t1[15:0]
	5:4	co_p4[25:24]	0x0E	15:0	co_t3[15:0]
	3:2	co_p1[25:24]	0x0F	15:0	co_p8[15:0]
1:0	co_p2[25:24]	0x10	15:8	co_p2[23:16]	
0x04	15:6		reserved	7:0	co_p1[23:16]
	5:4	co_t2[17:16]	0x11	15:8	co_p4[23:16]
	3:2	co_t3[17:16]		7:0	co_p5[23:16]
	1:0	co_t1[17:16]	0x12	15:8	co_p6[23:16]
0x05	15:0	co_p2[15:0]		7:0	co_p7[23:16]
0x06	15:0	co_p1[15:0]	0x13	15:8	co_p3[23:16]
0x07	15:0	co_p4[15:0]		7:0	reserved

## 1.10.2 Compensation formula

The ODR and OSR can be selected by selected by the oversampling\_setting in the C code. The IIR filter coefficient can also be set in the C code.

Using the driver C code provided by WF is strongly recommended. Please contact with WF for details.



# WF5803 Miniature Variometer Module

## 2 I<sup>2</sup>C interface

The I<sup>2</sup>C slave interface is compatible with Philips I<sup>2</sup>C specification. Standard and fast mode are supported. SDA and SCL are not pure open-drain. Both pads contain ESD protection diodes to VDD and GND. As the device does not perform clock stretching, the SCL structure is a high-Z input without drain capability.

The 7-bit device address is 1111000 (0x78). By programming the low 7bits of the 3<sup>rd</sup> data byte of NVM (address 0x02), see Table 12, the device address can be redefined.

### 2.1 I<sup>2</sup>C read status

Whenever the device is addressed in read mode (RW = '1') at address 11110001, the status byte is always the first output byte. For checking the status of the device, the I<sup>2</sup>C master must send NOACK and stop condition after the status byte, as shown in Figure 5.

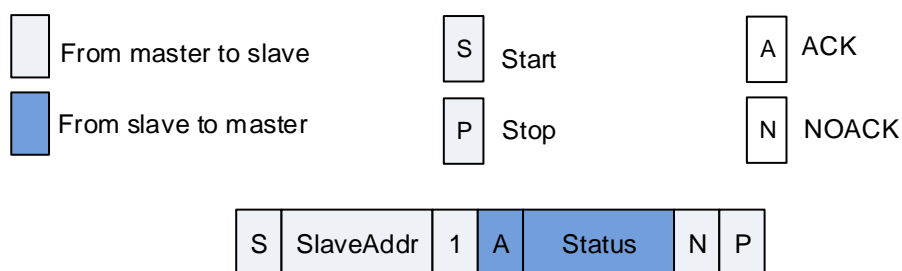

Figure 5 I<sup>2</sup>C read status

The status byte provide the information of the device. The information of each bit of the status byte is described in Table 8.

Table 8 Status byte

Status	Meaning	Description
Bit7	Reserved	Constant 0
Bit6	Power indication	"1" ADC is powered on; "0" ADC is powered off
Bit5	Busy indication	"1" Busy: The device is measuring pressure and temperature and the results are not ready yet. New I <sup>2</sup> C command will not be proceeded. "0" Idle: The recent I <sup>2</sup> C command has been executed and the data to be read is ready.
Bit4	Reserved	Constant 0
Bit3	Mode Status	"0" normal mode



# WF5803 Miniature Variometer Module



Status	Meaning	Description
		"1" test mode, only for testing
Bit2	Memory integrity/error flag	"0" The integrity check (CRC) of the NVM is passed. All the data in the NVM is correct. "1" The integrity check(CRC) of the NVM is failed. Some of the data in the NVM is error.
Bit1	Reserved	Constant 0
Bit0	Reserved	Constant 0

## 2.2 I<sup>2</sup>C read NVM

The NVM has a width of 16 bits. To read the 16-bit data from the NVM, first the address of the NVM must be sent in the write mode (I<sup>2</sup>C slave address 11110000). Then wait for at least 80µs. After this the data is ready, the slave is addressed in read mode (RW = '1') at address 11110001, after which the slave sends out status byte firstly followed with two bytes data until a NOACK and stop condition occurs, as shown in Figure 6.

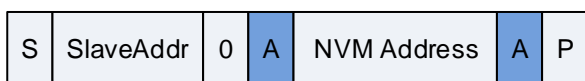

Figure 6 I<sup>2</sup>C read NVM

## 2.3 I<sup>2</sup>C write

The pressure or temperature measurement is triggered by sending the command in write mode, which is done by sending the slave address in write mode (RW = '0'), resulting in slave address 11110000. Then the master sends the command byte and the 16-bit command data. The transaction is ended by a stop condition, as shown in Figure 7.



Figure 7 I<sup>2</sup>C write command

The detail of the I<sup>2</sup>C command and command data is described in Table 11.



# WF5803 Miniature Variometer Module

Table 9 I<sup>2</sup>C commands

CMD, Data(HEX)	Measurement	Analog Front End Configuration
0xA0, 0x0000	Pressure measurement	AFE is configured by the pre-programmed setting in the NVM (address 0x14).
0xA1, 0xssss	Pressure measurement	AFE is configured by 0xssss, see data content and format in the NVM(address0x14)
0xA2, 0x0000	Pressure measurement with system auto-zero	AFE is configured by the pre-programmed setting in the NVM (address 0x14).
0xA3, 0xssss	Pressure measurement with system auto-zero	AFE is configured by 0xssss, see data content and format in the NVM(address0x14)
0xA4, 0x0000	Temperature measurement	AFE is configured by the pre-programmed setting in the NVM (address 0x14).
0xA5, 0xssss	Temperature measurement	AFE is configured by 0xssss, see data content and format in the NVM(address0x14)
0xA6, 0x0000	temperature measurement with system auto-zero	AFE is configured by the pre-programmed setting in the NVM (address 0x14).
0xA7, 0xssss	temperature measurement with system auto-zero	AFE is configured by 0xssss, see data content and format in the NVM(address0x14)

The format and purpose of configuration bits “0xssss” is the same with the definitions of the 16-bit data byte in the NVM with the address 0x14. System auto-zero mentioned in Table 9 is used for measuring the inherent system offset for the respective configuration which is only used in the software initialization process. The detail of the format is shown in Table 10.

Table 10 AFE setting format

Analog front end configuration format (ssss)		
Bit	Description	Definition
15:14	osr_t	Oversampling setting of temperature measurement
		00 : x4                      10 : x16



## WF5803 Miniature Variometer Module

Analog front end configuration format (ssss)		
		01 : x8                      11 : x32
13:11	osr_p	Oversampling setting of pressure measurement 111 : x0                      011 : x8 110 : x1                      010 : x16 101 : x2                      001 : x32 100 : x4                      000 : x64
10:8	A2D_Offset	ADC offset and resulting A2D input range <b>000 : 1/16 → [-1/16, 15/16] (Default value)</b> 001 : 2/16 → [-2/16, 14/16] 010 : 3/16 → [-3/16, 13/16] 011 : 4/16 → [-4/16, 12/16] 100 : 5/16 → [-5/16, 11/16] 101 : 6/16 → [-6/16, 10/16] 110 : 7/16 → [-7/16, 9/16] 111 : 8/16 → [-8/16, 8/16] <i>Use the default value is recommended.</i>
7:6	Clk_divider	ADC sampling clock frequency setting Use "00" is recommended.
5	Gain_polarity	Polarity of pre-amplifier for measuring pressure 0 : negative                      1 : positive
4:2	Gain_stage2	Gain setting for the 2nd pre-amplifier stage 000 : 1.1x                      100 : 1.5x 001 : 1.2x                      101 : 1.6x 010 : 1.3x                      110 : 1.7x 011 : 1.4x                      111 : 1.8x
1:0	Gain_stage1	Gain setting for the 1st pre-amplifier stage 00 : 12x                      10 : 30x 01 : 20x                      11 : 40x

### 2.4 I<sup>2</sup>C read measurement data

After the pressure or temperature measurement is triggered by sending relative I<sup>2</sup>C commands described in 2.3, WF5803 starts a measurement and puts the result in the output buffer. Depend on the OSR setting, the measurement will complete in several milliseconds, as shown in Table 2. Then the I<sup>2</sup>C master can read the pressure or temperature raw data. User can also regularly read the status via I<sup>2</sup>C to check the device is in busy or idle. The measurement is ready for reading if the status is idle.



# WF5803 Miniature Variometer Module

Pressure measurement data is always read in 24-bit format, as shown in Figure 8.

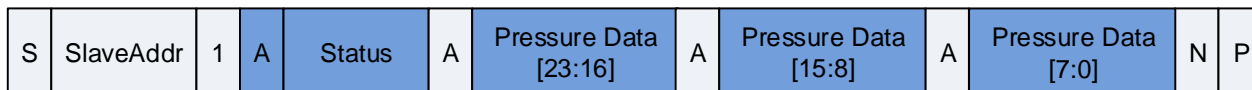

Figure 8 I<sup>2</sup>C read pressure data

Temperature measurement data can be read in 16-bit or 24-bit format depends on the resolution requirement of the application. For pressure compensation calculation, high 16-bit temperature data is enough.

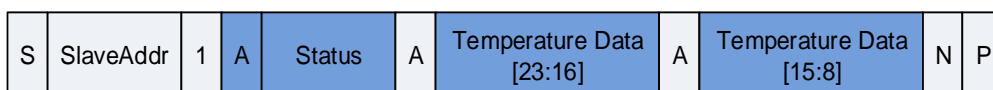

Figure 9 I<sup>2</sup>C read temperature data

## 2.5 I<sup>2</sup>C slave timing

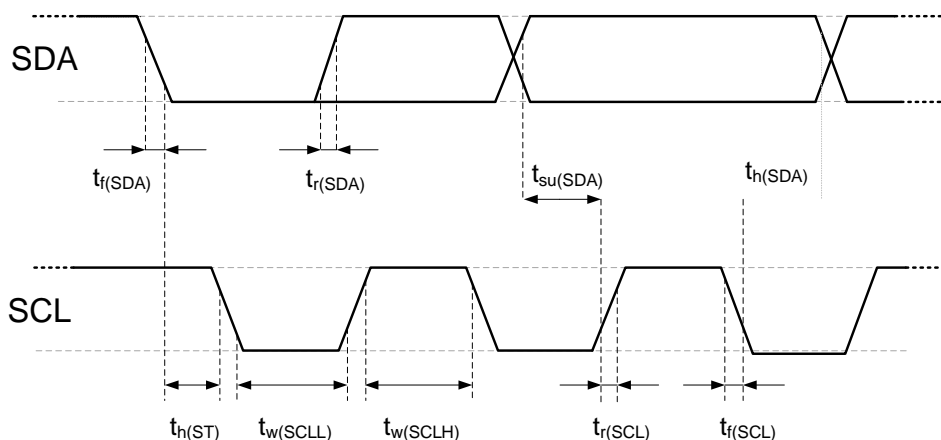

Figure 10 I<sup>2</sup>C timing diagram

Table 11 I<sup>2</sup>C timing



## WF5803 Miniature Variometer Module

Symbol	Parameter	I <sup>2</sup> C standard mode		I <sup>2</sup> C fast mode		Unit
		Min	Max	Min	Max	
f <sub>(SCL)</sub>	SCL clock frequency	0	100	0	400	kHz
t <sub>w(SCLL)</sub>	SCL clock low time	4.7		1.3		μs
t <sub>w(SCLH)</sub>	SCL clock high time	4.0		0.6		μs
t <sub>su(SDA)</sub>	SDA setup time	250		100		ns
t <sub>h(SDA)</sub>	SDA data hold time	0.09	3.45	0.02	0.9	μs

Notes: Measurement points are done at 0.2 V<sub>DD</sub> and 0.8 V<sub>DD</sub>, for both ports.



# WF5803 Miniature Variometer Module

## 3 Global memory map

The Non-volatile memory has a width of 16 bits. There are several memory which are reserved; they should not be written to, otherwise the CRC bit in the status would not be correct. The detail of the memory is given in Table 12.

Table 12 Memory map

NVM Addr (HEX)	Bit Range	Default Value	Description	Notes/Explanations
0x00	15:0	0x0000	cust_ID0	Custom ID byte 0
0x01	15:0	0x0000	cust_ID1	Custom ID byte 1
0x02	15:7	0x000	-	Reserved
	6:0	0x00	slave_Addr	I <sup>2</sup> C slave address; valid 0x01~0x7F. If slave_addr=0x00, then 0x78 is used. Note: address codes 0x04 to 0x07 are reserved for entering I <sup>2</sup> C High Speed Mode.
0x03	15	Individual	co_p8[16]	Bit [16] of calibration coefficient co_p8
	14	0x0	reserved	reserved
	13:12	Individual	co_p3[25:24]	Bits [25:24] of calibration coefficient co_p3
	11:10	Individual	co_p6[25:24]	Bits [25:24] of calibration coefficient co_p6
	9:8	Individual	co_p7[25:24]	Bits [25:24] of calibration coefficient co_p7
	7:6	Individual	co_p5[25:24]	Bits [25:24] of calibration coefficient co_p5
	5:4	Individual	co_p4[25:24]	Bits [25:24] of calibration coefficient co_p4
	3:2	Individual	co_p1[25:24]	Bits [25:24] of calibration coefficient co_p1
1:0	Individual	co_p2[25:24]	Bits [25:24] of calibration coefficient co_p2	
0x04	15:6	0x000	reserved	reserved
	5:4	Individual	co_t2[17:16]	Bits [17:16] of calibration coefficient co_t2
	3:2	Individual	co_t3[17:16]	Bits [17:16] of calibration coefficient co_t3
	1:0	Individual	co_t1[17:16]	Bits [17:16] of calibration coefficient co_t1
0x05	15:0	Individual	co_p2[15:0]	Bits [15:0] of calibration coefficient co_p2
0x06	15:0	Individual	co_p1[15:0]	Bits [15:0] of calibration coefficient co_p1
0x07	15:0	Individual	co_p4[15:0]	Bits [15:0] of calibration coefficient co_p4
0x08	15:0	Individual	co_p5[15:0]	Bits [15:0] of calibration coefficient co_p5
0x09	15:0	Individual	co_p7[15:0]	Bits [15:0] of calibration coefficient co_p7
0x0A	15:0	Individual	co_p6[15:0]	Bits [15:0] of calibration coefficient co_p6
0x0B	15:0	Individual	co_p3[15:0]	Bits [15:0] of calibration coefficient co_p3
0x0C	15:0	Individual	co_t2[15:0]	Bits [15:0] of calibration coefficient co_t2
0x0D	15:0	Individual	co_t1[15:0]	Bits [15:0] of calibration coefficient co_t1
0x0E	15:0	Individual	co_t3[15:0]	Bits [15:0] of calibration coefficient co_t3



# WF5803 Miniature Variometer Module

NVM Addr (HEX)	Bit Range	Default Value	Description	Notes/Explanations
0x0F	15:0	Individual	co_p8[15:0]	Bits [15:0] of calibration coefficient co_p8
0x10	15:8	Individual	co_p2[23:16]	Bits [23:16] of calibration coefficient co_p2
	7:0	Individual	co_p1[23:16]	Bits [23:16] of calibration coefficient co_p1
0x11	15:8	Individual	co_p4[23:16]	Bits [23:16] of calibration coefficient co_p4
	7:0	Individual	co_p5[23:16]	Bits [23:16] of calibration coefficient co_p5
0x12	15:8	Individual	co_p6[23:16]	Bits [23:16] of calibration coefficient co_p6
	7:0	Individual	co_p7[23:16]	Bits [23:16] of calibration coefficient co_p7
0x13	15:8	Individual	co_p3[23:16]	Bits [23:16] of calibration coefficient co_p3
	7:0	0x00	reserved	reserved
0x14	15:14	0x00	osr_t	Default oversampling setting of temperature measurement
	13:11	0x00	osr_p	Default oversampling setting of pressure measurement
	10:8	0x0	A2D_Offset	ADC offset and resulting A2D input range
	7:6	0x0	Clk_divider	ADC sampling clock frequency setting
	5	0x1	Gain_polarity	Polarity of pre-amplifier for measuring pressure
	4:2	Individual	Gain_stage2	Gain setting for the 2nd pre-amplifier stage
1:0	Individual	Gain_stage1	Gain setting for the 1st pre-amplifier stage	
0x15~ 0x1E	15:13	0x0000	Reversed	Reserved
0x1F	15:0	Individual	ChecksumC	Integrity checksum (CRC)



# WF5803 Miniature Variometer Module

## PACKAGE OUTLINE AND PIN CONFIGURATION

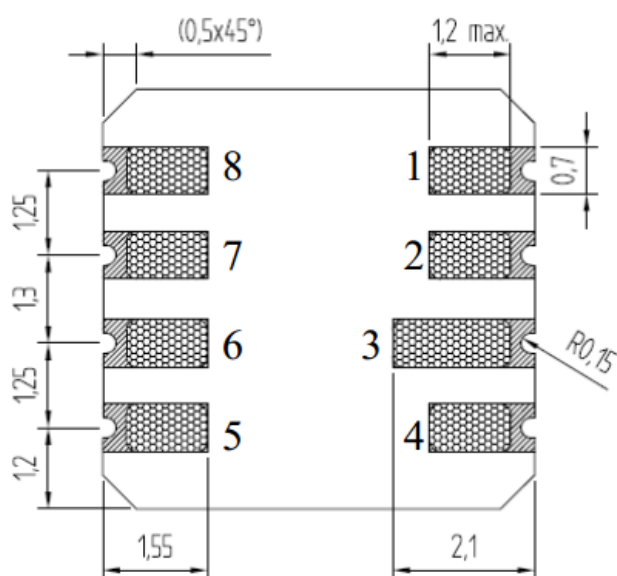
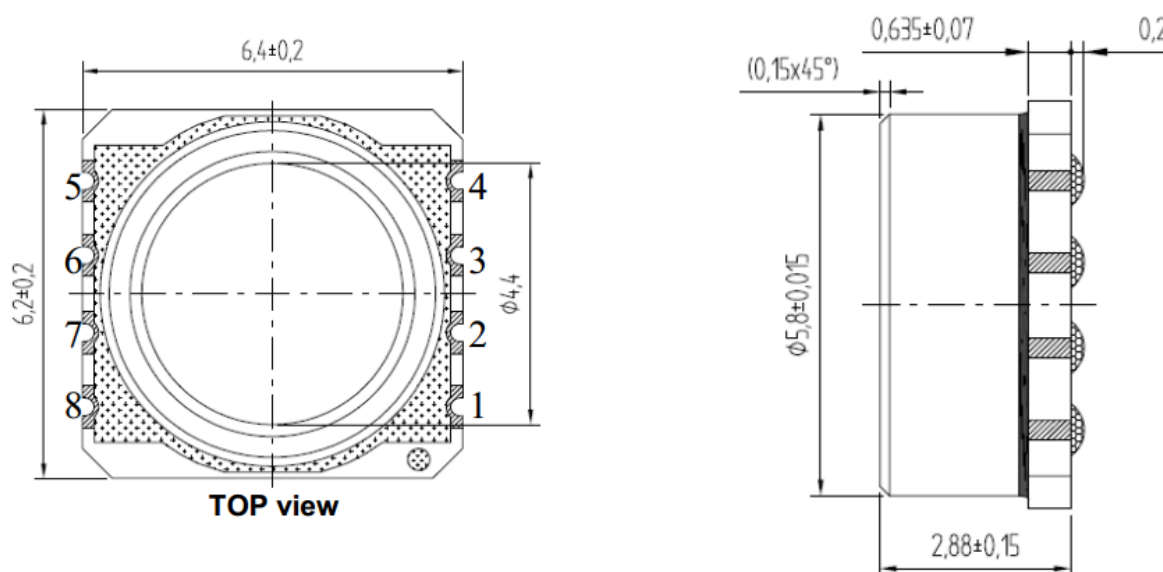

Pin	Name	Function
1	SCLK	Serial data clock
2	GND	Ground
3	NC	
4	NC	
5	VDD	Positive supply voltage
6	NC	
7	SDA	Serial data
8	NC	



## WF5803 Miniature Variometer Module

Notes:

1. All dimensions are in mm.
2. General tolerance +/-0.1mm.