

High Accuracy, Digital Barometric Pressure and Temperature Sensor

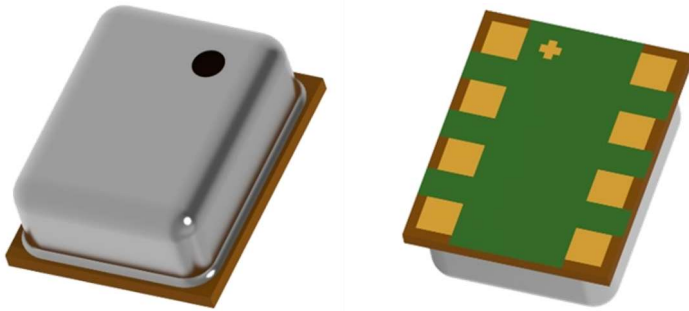

Key features

- Pressure range: 500 ~ 1100hPa
- Temperature range: -40...+85°C
- Supply voltage: 2.8V DC(Typ.)
- Package: LGA package with metal lid
- Relative accuracy: $\pm 0.06\text{hPa}$
- Absolute accuracy: $\pm 1\text{hPa}$
- Temperature accuracy: $\pm 1.0^\circ\text{C}$
- Pressure temperature sensitivity: $\leq 1.0\text{Pa/K}$
- Average current consumption: average supply current of 1.8 μA at idle
- I²C, Embedded 24-bit ADC
- DSP mode
- Pb-free, halogen-free and RoHS compliant
- MSL 1 compliant

Typical applications

- Unmanned aerial vehicle cruises
- In- and out-door navigation
- Leisure and sports
- Weather forecast
- Vertical velocity indication (rise/sink speed)

Description

The sensor is a digital sensor with pressure and temperature measurement. The sensor module is housed in an extremely compact 8 PIN LGA package with a footprint of only 2.5x2.0 mm² and 0.95mm package height. Its small dimensions and its low power consumption make the sensor suitable for mobile applications, GPS modules and wearable devices.

Notes

Particles can influence the performance of the pressure sensor, we strongly recommend you to introduce special measures to avoid deposition of particles on the MEMS membrane or screen particles after assembly as the assembly process is considered to be the main root cause for particle generation.

1. Product Description

The WF286A is a low-power, high-accuracy barometric pressure and temperature sensor. It comes in the LGA package with digital I²C interfaces. The pressure sensor element is based on a capacitive sensing principle which guarantees high precision during temperature changes. Its small dimensions make the pressure sensor for UAV (unmanned aerial vehicle) cruises, mobile applications, GPS modules and wearable devices.

The sensor's internal signal processor converts the output from the pressure and temperature sensor elements to 24-bit results. Each pressure sensor has been calibrated individually and contains calibration coefficients. The coefficients are used to convert the measurement results to true pressure and temperature values. The integrated FIFO of the sensor can store the latest 32 output results.

2. Pin configuration and Description

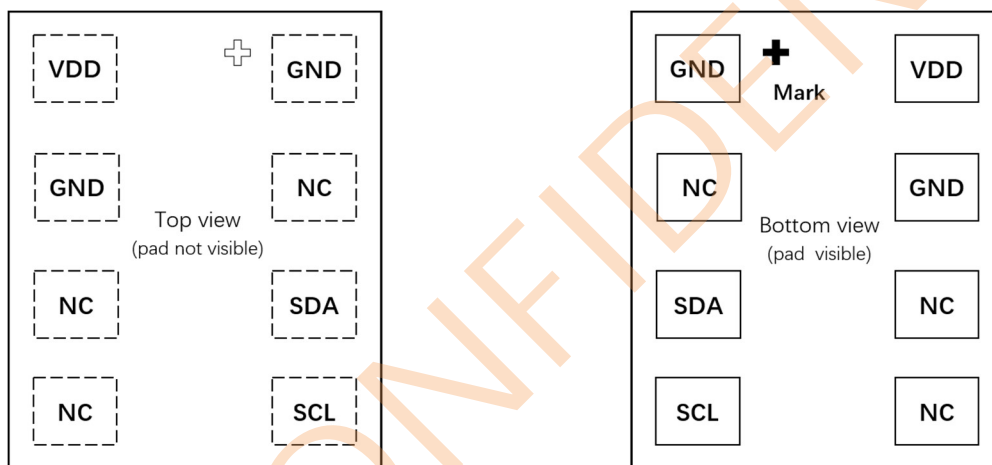

Figure 1: Layout pin configuration of the sensor

Table 1: Pin configuration

PIN	Name	Description
1	GND	Ground
2	NC	Not Connect
3	SDA	I ² C bus bi-Directional Data
4	SCL	I ² C Serial Clock
5	NC	Not Connect
6	NC	Not Connect
7	GND	Ground
8	VDD	Supply Voltage



3. Electrical characteristics

Table 2: Electrical characteristics

Parameter	Symbol	Condition	Min	Type	Max	Units
Operating temperature range	T _{range}	Operational	-40	25	85	°C
Operating pressure range	P _{range}		500		1100	hPa
Supply voltage	VDD			2.8	3.3	V
Supply current	IDD	Current consumption in idle state, (HP = 0, 25 °C)		1.8		uA
Absolute pressure accuracy	P _A	500~1100hPa@0~65°C		±1		hPa
Relative pressure accuracy	P _R	950~1050hPa@+25~+45 °C		±6		Pa
Pressure resolution	P _{res}	1 LSB		1/64		Pa
Offset temperature coefficient	TCO	1000hPa@+25~45°C		±1.0		Pa/K
Noise in pressure	P _{noise}	2ms conversion, 1000hPa, 25°C 16×P _{OVS} , 4×T _{OVS}		0.45		PaRMS
Absolute temperature accuracy	T _A	0~65°C		±1.0		°C
Solder drifts		1000hPa, 25°C, 24 h after soldering	-1		+1	hPa
Long term stability		12 month		±1		hPa

4. Absolute maximum ratings

Table 3: Absolute Maximum Ratings

Symbol	Parameter	Min	Max	Units
VDD	Supply Voltage	-0.3	6	V
SDA/SCL	Voltage at IO Pins	-0.3	3.6	V
ESD _{HBM}	Electrostatic Discharge HBM	±2000		V
ESD _{CDM}	Electrostatic Discharge CDM	±500		V
T _{STRG}	Storage temperature	-40	85	°C
P _{MAX}	Survival pressure		5000	hPa

5. Functional description

The WF286A integrates an absolute pressure sensor, a temperature sensor and an ASIC which performs A/D conversions and provides the pressure and temperature data through a digital interface.

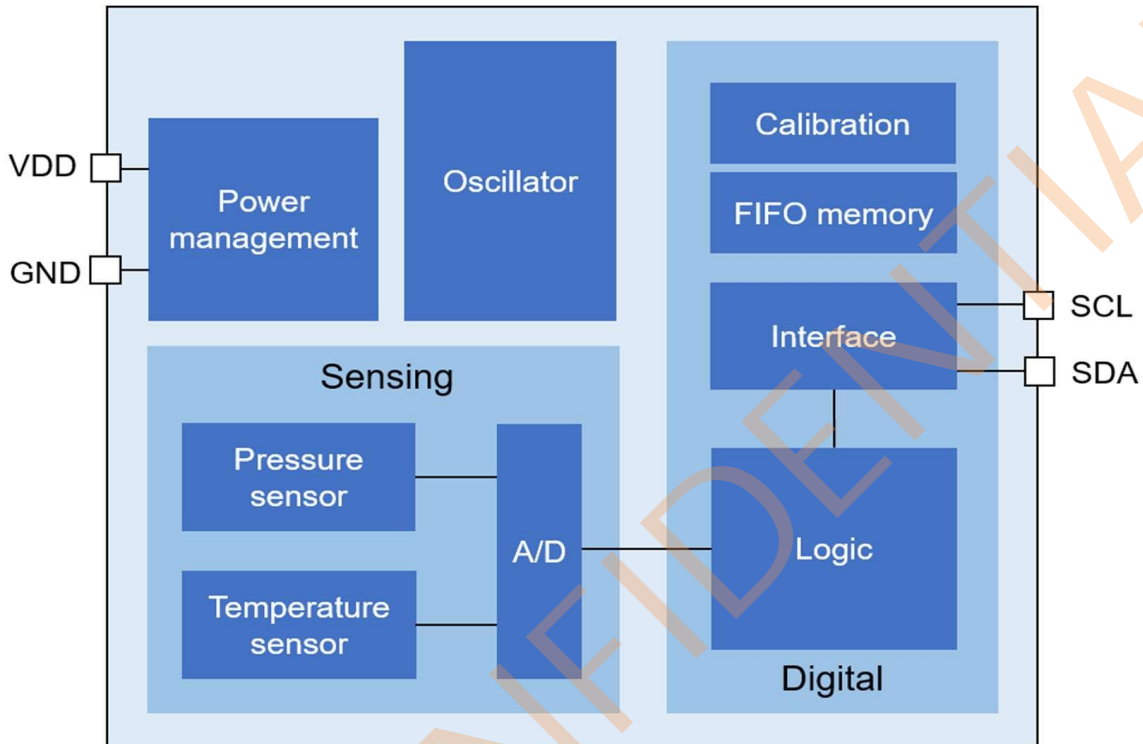

Figure 2: Block diagram of WF286A

The WF286A is a sensor capable of providing fast and accurate temperature measurements at low current consumption. To meet the requirements of different use cases the WF286A offers very high configuration flexibility.

The configurable features are:

- Operating mode
 - Continuous
 - Pulsed
 - Single Shot
- FIFO
- Ultra-low power mode

5.1 Measurement modes

The sensor starts powering-up after reaching the power-up voltage VDD. The sensor enters the default idle mode, in which no measurements are performed, and the sensor configuration can be chosen. By switching the START bit to 1, the sensor starts measuring pressure and temperature. The sensor can be operated in three measurement modes, which can be selected with the value of STBY_T (see also Figure 3):

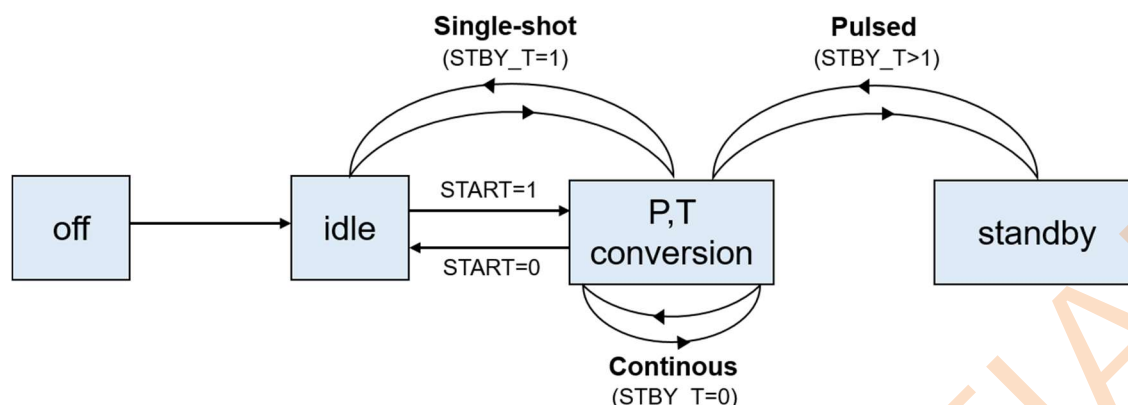

Figure 3: Simplified schematic of measurement modes

- If $STBY_T = 0$ the device performs continuous measurements (temperature and pressure).
- If $STBY_T > 1$ the device alternates a measurement phase and a standby phase (pulsed operation)
- If $STBY_T = 1$ the device performs a single measurement (temperature and pressure) and goes back into idle mode.

The length of the standby phase can be selected from 10 ms to 600 s by writing on $STBY_T$.

5.2 FIFO

A FIFO buffer is available to store 32 pressure values. It is enabled by $MODE_CFG.FIFO_MODE$.

The FIFO works as a circular buffer, with a write pointer to store new pressure values and a read pointer to retrieve them. The structure is shown in Figure 4. The write pointer increases whenever a new measurement is completed and the new value is written to the buffer. The pointer will increase even when the buffer is full, overwriting the oldest values recorded. Reads from $PRESS_OUT_H$ increase the read pointer until it reaches the write pointer, subsequent reads will return 0. Both pointers wrap around (31 increments to 0).

The entire FIFO can be quickly read from $PRESS_OUT_F$. A continuous read past address 0x29 will cycle the memory read pointer back to 0x27, increasing at the same time the FIFO read pointer. In this way the entire FIFO buffer can be transferred without addressing overhead.

NOTE: In order to read more than one value it is necessary to set the HP bit in $MODE_CFG$.

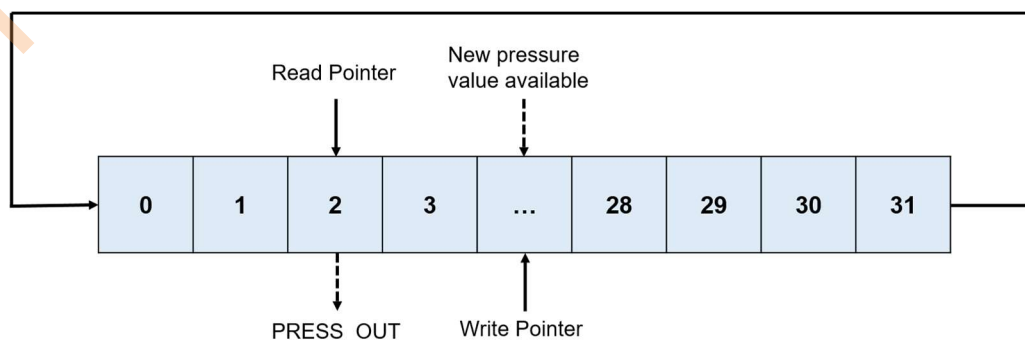

Figure 4: FIFO structure

FIFO operations are controlled by FIFO_CFG. The FIFO can be cleared by setting FP_CLEAR. The FIFO status is available in FIFO_STAT, and the current FIFO fill level (number of elements available) can be read from FP_FILL. When the FIFO is empty, FE is set. When the FIFO is full, FF is set. If a new pressure value arrives while FIFO is full, the overrun bit DATA_STAT.PO is set, and the oldest value is overwritten.

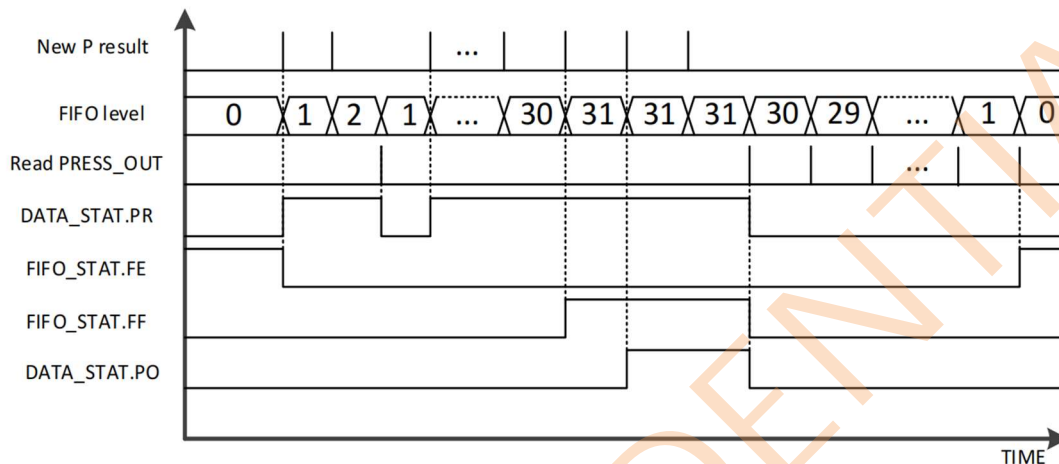

Figure 5: Sample FIFO timing diagram

5.3 Ultra low power mode

Power consumption can be reduced at the expense of some functionality.

If the HP bit is 0 (see MODE_CFG), the power consumption in idle and standby state is low and only the following registers are accessible via I²C: MODE_CFG, DATA_STAT, FIFO_STAT, PRESS_OUT, TEMP_OUT.

The use of this feature is recommended for every measurement mode except continuous mode. By setting HP to 1, the power consumption increases and all registers become available.

6. I²C interface

The sensor is an I²C slave device with a fixed 7-bit address 0x20. The sensor applies all mandatory I²C protocol features for slaves: START, STOP, Acknowledge, 7-bit slave address. None of the other optional features (10-bit slave address, general call, software reset or Device ID) are supported, nor are the master features (Synchronization, Arbitration, START byte).

The sensor uses a register model to interact with the host. This means that the I²C master can directly read or write values to one of the registers by first sending the single byte register address.

6.1 I²C write operation

The write operation is a single continuous transaction:

- The I²C master sends the START (S) condition which blocks the bus.
- The I²C Master sends the 7-bit slave address and 0 into the R bit (indicates a write transaction, the byte sent would be 0x40). The transaction will be acknowledged by the slave (ACK).

- The I²C Master then sends the address of the first register to write. The transaction will be acknowledged by the slave (ACK). (or not acknowledged (NACK) when the address is not writable)
- The I²C Master then sends one or more data bytes which are written into sequential registers (if valid) until the transaction is concluded with a STOP (P) condition.

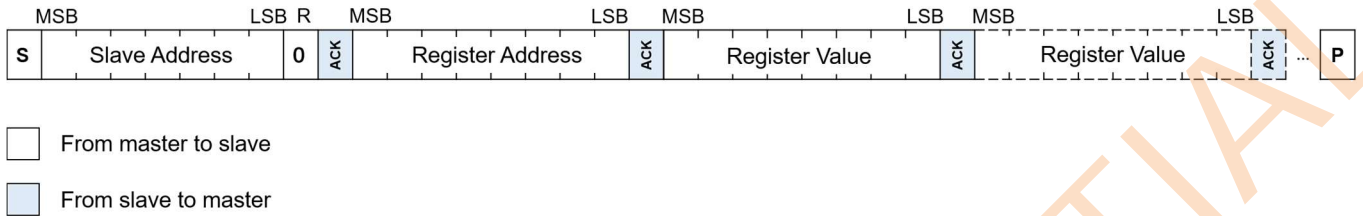

Figure 6: I²C write operation

6.2 I²C read operation

A read transaction (see Figure 7) starts with a write (of the register address), followed by a read. Consequently, it has the following format:

- The write specifies the register address:
- The I²C Master sends a START condition.
- The I²C Master sends the 7-bit slave address and 0 into the R bit (indicates a write transaction, the byte sent would be 0x40). The transaction will be acknowledged by the slave (ACK).
- The I²C Master then sends the address of the first register to read.

It is followed by the read sequence:

- The I²C Master sends again a START condition.
- The I²C Master sends the 7-bit slave address and 1 into the R bit (indicates a read transaction, the byte sent would be 0x41).
- The I²C slave then sends 1-n data bytes from sequential registers (if valid), each acknowledged by the master until the transaction is concluded with a STOP condition.

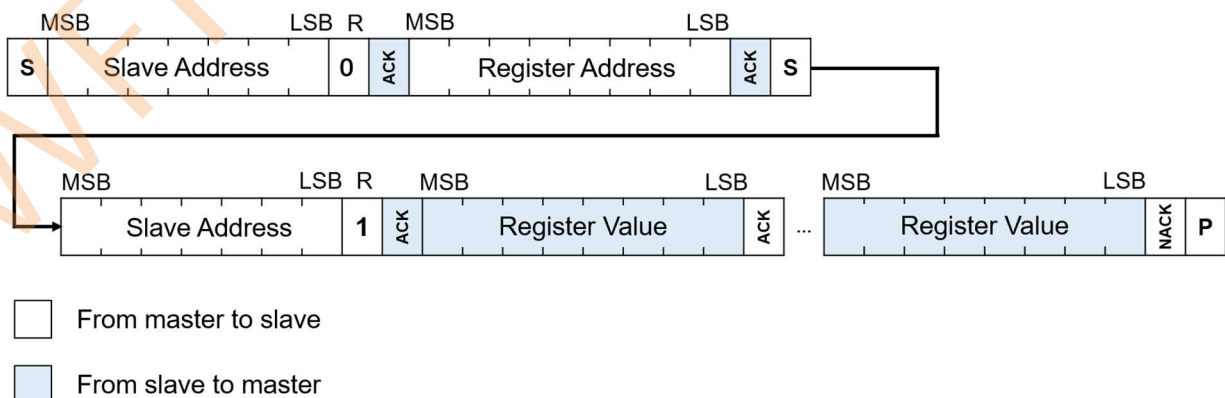

Figure 7: I²C read operation

6.3 High speed mode

The bus operation speed is limited to 400 kHz unless a high speed enable command (00001xxx) is issued by the master device as the first byte after START condition. This command is not acknowledged (NACK) by the slave. The high-speed operation allows data transfer frequencies up to 3.4 MHz. The input filters on the serial interface (SDA and SCL) are adapted to a higher bandwidth. After the high-speed command, the master transmits the slave address to invoke a data transfer. The bus keeps operating at the highest operating frequency until the master issues a STOP condition. Upon reception of the STOP condition by the slave, the input filters are switched to their initial time constants, which allow only up to 400 kHz transfer rates.

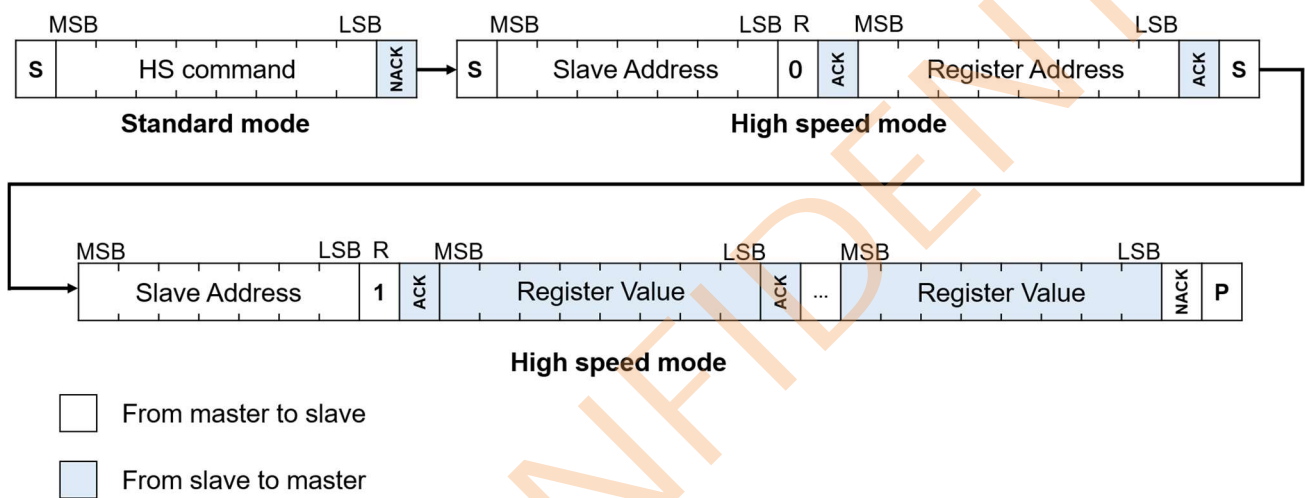

Figure 8: I²C high-speed read operation

6.4 Timing specifications

The sensor is compliant to the I²C bus specifications [UM1020, I²C-bus specification and user manual, Rev. 6, 4 April 2014].

Table 4: I2C timing parameters

Parameter	Symbol	Units	Fast Mode		High-Speed Mode	
			Min	Max	Min	Max
SCL frequency	Fscl	kHz		400		3400
SCL low time	Twscll	us	1.3		0.16	
SCL high time	Twsclh	us	0.6		0.06	
SCL setup time	Tsup	ns	100		10	
SDA hold time(host transmits)	Th	ns	0	-	0	-
SDA hold time(device transmits)	Tv	ns	40	900	20	160
SCL rise time	TrCL	ns		300	10	40
SCL fall time	TfCL	ns		300	10	40
SDA rise time	TrDA	ns		300	10	80
SDA fall time	TfDA	ns		300	10	80
Start condition hold time	Thst	us	0.6		0.16	
Repeated start condition setup time	Tsupst	us	0.6		0.16	
Stop condition setup time	Tsupsp	us	0.6		0.16	
Bus free time between start-stop	Twspst	us	1.3		0.16	
Load capacitance	CL	pF		400		100

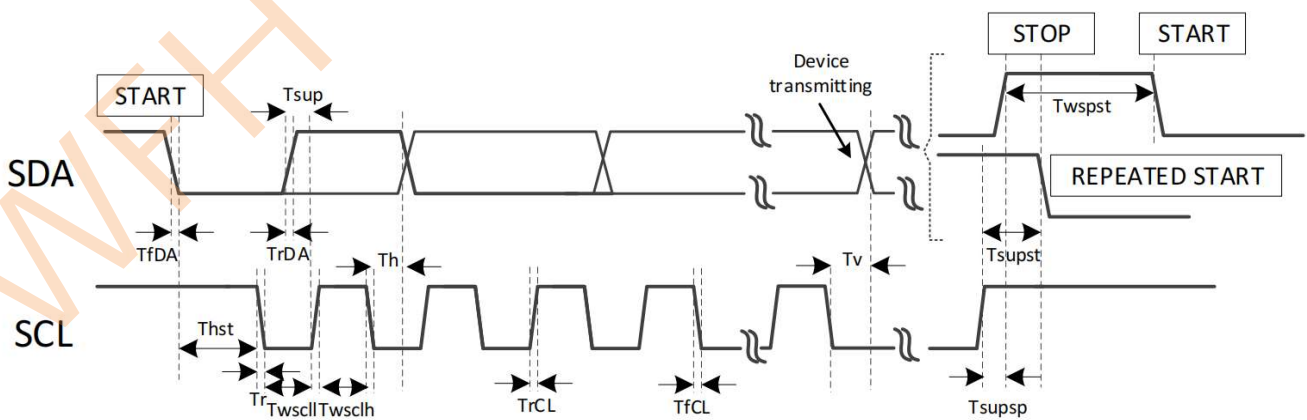

Figure 9: I²C timing diagram



7. Registers

7.1 Register map

This section describes the registers of the WF286A

Table 5: Register map

Addr.	Name	Def.	R/W	7	6	5	4	3	2	1	0	Description
0x02	UID0	-	R	UID0								Unit ID[7:0]
0x03	UID1	-	R	UID1								Unit ID[15:8]
0x04	UID2	-	R	UID2								Unit ID[23:16]
0x05	UID3	-	R	UID3								Unit ID[31:24]
0x06	MODE_CFG	0x03	RWrw	HP	FIFO_MODE		START	RESET	0	MEAS_T	MEAS_P	Device configuration
0x07	MEAS_CFG	0x08	RW	0	0		P_CONV		PT_RATE			Conversion time, P/T rate
0x08	STBY_CFG	0x00	RWw	0				STBY_T				Standby time configuration
0x09	OVS_CFG	0x00	RW	0	OVSP			OVST				Oversampling settings
0x13	FIFO_CFG	0x00	RW	0	FP_CL EAR	FP_FILL_TH						FIFO configuration
0x14	DATA_STAT	0x00	Rr	0			PO	TO	PR	TR		Measurement data status
0x15	FIFO_STAT	0x02	R	FP_FILL				FF	FE	FH		FIFO status
0x17	PRESS_OUT_XL	0x00	Rry	PRESS_OUT_XL								Pressure value [7:0]
0x18	PRESS_OUT_L	0x00	Rry	PRESS_OUT_L								Pressure value [15:8]
0x19	PRESS_OUT_H	0x00	Rry	PRESS_OUT_H								Pressure value [23:16]
0x1A	TEMP_OUT_L	0x00	Rr	TEMP_OUT_L								Temperature value [7:0]
0x1B	TEMP_OUT_H	0x00	Rr	TEMP_OUT_H								Temperature value [15:8]
0x27	PRESS_OUT_F_XL	0x00	RFry	PRESS_OUT_F_XL								Pressure value [7:0]
0x28	PRESS_OUT_F_L	0x00	RFry	PRESS_OUT_F_L								Pressure value [15:8]
0x29	PRESS_OUT_F_H	0x00	RFry	PRESS_OUT_F_H								FIFO Pressure value[23:16]

Legend :(the letters in the R/W column define the colors of the register fields)

W: Write access in low power mode.

w: Write access in ultra-low power mode.

R: Read access in low power mode.

r: Read access in ultra-low power mode.

F: Address counter wraps. See text.

y: Read only the last value in ultra-low power mode.



7.2 UID(Address 0x02~0x05)

Table 6: Register UID

Address	Bits	Field Name	Default	Access	Field Description
0x02	7:0	UID0		R	Least significant byte(LSB) of UID
0x03	15:8	UID1		R	Second byte of UID
0x04	23:16	UID2		R	Third byte of UID
0x05	31:24	UID3		R	Most significant byte(MSB) of UID

7.3 MODE_CFG (Address 0x06)

Table 7: Register MODE_CFG

Address 0x06		MODE_CFG			Default: 0x03
Bits	Field Name	Default	Access	Field Description	
7	HP	0b0	RWrw	High Power Bit 0b1: All registers are accessible via I ² C; power consumption is high. A delay of 0.5ms is required from high power enable to the next I ² C access. 0b0: The following registers are accessible via I ² C: MODE_CFG, DATA_STAT, FIFO_STAT,PRESS_OUT,TEMP_OUT. Power consumption is low.	
6:5	FIFO_MODE	0b00	RWrw	Pressure data path 0b00: Direct path 0b01: FIFO	
4	START	0b0	RWrw	Operating mode configuration 0b0: Stop measurement (idle mode) 0b1: Start measurement (measurement mode) Idle Mode is intended for configuration before running an active sensing mode. This bit is automatically reset in case of one-shot operation, after the required measurements have been performed	
3	RESET	0b0	RWrw	Device reset 0b1: The device is reset to the power-on configuration. RESET is automatically cleared. Device reset should be performed with HP bit at 0; the suggested reset sequence is : 0x08 → wait 0.5ms → 0x80 → wait 0.5ms → configure device	



2	X	0b0	RWrw	Reserved – must be set to default value
1	MEAS_T	0b1	RWrw	See Table 8
0	MEAS_P	0b1	RWrw	

Table 8: Measurement selection with MEAS_T and MEAS_P

MEAS_T	MEAS_P	
0	1	Only pressure measurements are enabled; the device will begin with a temperature measurement, then it will continue measuring only pressure.
1	0	Only temperature measurement is enabled.
1	1	Pressure and temperature measurements are enabled. PT_RATE controls the temperature interleaving timer.

7.4 MEAS_CFG (Address 0x07)

Table 9: Register MEAS_CFG

Address 0x07		MEAS_CFG		Default: 0x08
Bits	Field Name	Default	Access	Field Description
7:5	X	0b000	RW	Reserved – needs to be set to default value
4:3	P_CONV	0b01	RW	Pressure ADC conversion time. See Table 10
2:0	PT_RATE	0b000	RW	Determines the ratio between P and T measurements as produced by the measurement engine. See Table 11

Table 10: Typical pressure ADC conversion time

P_CONV [1:0]	Conversion time [ms] First conversion	Conversion time [ms] Next conversions
0	4	1
1	8	2
2	16	4

Table 11: PT_RATE

PT_RATE [2:0]	P/T rate
0	1
1	4
2	8
3	16
4	32
5	64
6	128
7	256

7.5 STBY_CFG (Address 0x08)

Table 12: Register STBY_CFG

Address 0x08		STBY_CFG			Default: 0x00
Bits	Field Name	Default	Access	Command	
7:4	X	0b0	RWw	Reserved – needs to be set to default value	
3:0	STBY_T	0b0	RWw	Each measurement will be followed by a standby phase (see Table 13)	

Table 13: Standby pauses in-between measurements

STBY_T [3:0]	Standby duration (ms)
0	Continuous operation
1	One-shot operation(device returns to idle after one measurement is produced by the measurement engine)
2	10
3	20
4	30



5	50
6	100
7	250
8	500
9	750
10	1000
11	2000
12	5000
13	10000
14	60000
15	600000

7.6 OVS_CFG (Address 0x09)

Oversampling measures the average over of a certain number of samples. Oversampling applies to all measurement modes.

Table 14: Register OVS_CFG

Address 0x09		OVS_CFG			Default: 0x00
Bits	Field Name	Default	Access	Field Description	
7:6	X	0b00	RW	Reserved – needs to be set to default value	
5:3	OVSP	0b000	RW	Oversampling of pressure measurements(see Table 15)	
2:0	OVST	0b000	RW	Oversampling of temperature measurements(see Table 16)	

Table 15: Oversampling of pressure measurements

OVSP [5:3]	Number of averages
0	1
1	2

2	4
3	8
4	16
5	32
6	64
7	128

Table 16: Oversampling of temperature measurements

OVST [2:0]	Number of averages
0	1
1	2
2	4
3	8
4	16
5	32
6	64
7	128

7.7 FIFO_CFG (Address 0x13)

FIFO configuration register

Table 17: Register FIFO_CFG

Address 0x13		DATA_STAT			Default: 0x00
Bits	Field Name	Default	Access	Field Description	
7:6	X	0b00	RW	Reserved, must be set to default value	
5	FP_CLEAR	0x00	RW	FIFO clear. 0b1: the content of the FIFO is cleared;	



				FP_CLEAR is automatically cleared after the operation. 0b0: no operation
4:0	FP_FILL_TH	0x00	RW	FIFO level threshold. The value is used as target for interrupt and status generation.

7.8 DATA_STAT (Address 0x14)

Data status register

Table 18: Register DATA_STAT

Address 0x14		DATA_STAT			Default: 0x00
Bits	Field Name	Default	Access	Field Description	
7:4	X	0x0	Rr	Reserved	
3	PO	0b0	Rr	Pressure overwrite With FIFO disabled, PO is undefined.	
2	TO	0b0	Rr	Temperature overwrite This bit is set when a new temperature measurement is produced by the measurement engine and the previous data was not read. TO is cleared after reading TEMP_OUT_H.	
1	PR	0b0	Rr	Pressure ready. This bit is set when new pressure data becomes available. PR is cleared after reading PRESS_OUT_H.	
0	TR	0b0	Rr	Temperature ready. This bit is set when new temperature data becomes available. TR is cleared after reading TEMP_OUT_H.	

7.9 FIFO_STAT (Address 0x15)

FIFO status register

Table 19: Register FIFO_STAT

Address 0x15		FIFO_STAT			Default: 0x02
Bits	Field Name	Default	Access	Field Description	
7:3	FP_FILL	0x0	R	FIFO level Fill level of the pressure FIFO. FP_FILL is equal	



				to 0x1F when FIFO has 31 but also 32 elements.
2	FF	0b0	R	FF is set when the FIFO is enabled and is full(32 elements)
1	FE	0b1	R	FE is set when the FIFO is enabled and is empty(0 elements).
0	FH	0b0	R	FH is set when is enabled and the number of elements is greater than FP_FILL_TH.

7.10 PRESS_OUT (Address 0x17~0x19)

This 3-byte register contains a 24-bit unsigned integer representing the pressure in 1/64 Pa. A read on this register extracts one element from the FIFO if the FIFO is enabled by FIFO_MODE = 1. When the FIFO is empty, the read returns 0x000000. HP = 1 must be set for reading from the FIFO.

When the FIFO is not enabled (bypass), reads from this register return the latest measurement result. If readouts occur faster than measurements, values are repeated.

To ensure a consistent value during readout, PRESS_OUT registers are double buffered. When PRESS_OUT_XL is read, the device copies all bytes from the internal measurement registers to the I²C registers, then reads are always directly from the I²C registers. The double buffering is thus only available if all PRESS_OUT registers are read within the same I²C transaction. If the application does not support reading multiple bytes at once, then the user must ensure that the PRESS_OUT register is not updated during the reading. This can be achieved by reading quickly after an interrupt occurred, or by using the single-shot mode (STBY_CFG = 1).

Please note that the hardware implementation of this double buffering does not guarantee the alignment between data ready flags and data if they are accessed in the same I²C transaction. It is advised to access the flags in a separate transaction.

Table 20: Register PRESS_OUT

PRESS_OUT					
Address	Bits	Field Name	Default	Access	Field Description
0x17	7:0	PRESS_OUT_XL	0x00	Rry	Least significant byte (LSB) of PRESS_OUT
0x18	15:8	PRESS_OUT_L	0x00	Rry	Middle byte of PRESS_OUT
0x19	23:16	PRESS_OUT_H	0x00	Rry	Most significant byte(MSB) of PRESS_OUT

7.11 TEMP_OUT (Address 0x1A~0x1B)

This 2-byte register contains a 16-bit unsigned integer representing the temperature in 1/128 K. Reads from this register return the latest measurement result. If reads occur faster than measurements, values are repeated.



To ensure a consistent value during readout, TEMP_OUT registers are double buffered. When TEMP_OUT_L is read, the device copies all bytes from the internal measurement registers to the I²C registers, then readouts are always directly from the I²C registers. The hardware implementation does to guarantee the alignment between data ready flags and data if they are accessed in the same I²C transition; it is advised to access the flags separately from the data. But please note that double buffering only works for TEMP_OUT if TEMP_OUT_L and TEMP_OUT_H are read in the same I²C transaction with auto-increment of the register address.

Table 21: Register TEMP_OUT

TEMP_OUT					
Address	Bits	Field Name	Default	Access	Field Description
0x1A	7:0	TEMP_OUT_L	0x00	Rr	Least significant byte(LSB) of TEMP_OUT
0x1B	15:8	TEMP_OUT_H	0x00	Rr	Most significant byte(MSB) of TEMP_OUT

7.12 PRESS_OUT_F (Address 0x27~0x29)

This register is the same as PRESS_OUT, except that reading in a single I²C transaction wraps around from address 0x29 to 0x27. A single I²C transaction can thus read multiple P measurements from the FIFO.

The HP bit of the MODE_CFG register must be 1 when reading this register to access the FIFO.

Table 22: Register PRESS_OUT_F

PRESS_OUT_F					
Addr.	Bits	Field Name	Default	Access	Field Description
0x27	7:0	PRESS_OUT_F_XL	0x00	RFry	Least significant byte (LSB) of PRESS_OUT_F
0x28	15:8	PRESS_OUT_F_L	0x00	RFry	Middle byte of PRESS_OUT_F
0x29	23:16	PRESS_OUT_F_H	0x00	RFry	Most significant byte(MSB) of PRESS_OUT_F

8. Application

8.1 Application circuit

The application circuit example uses the I²C serial interface.

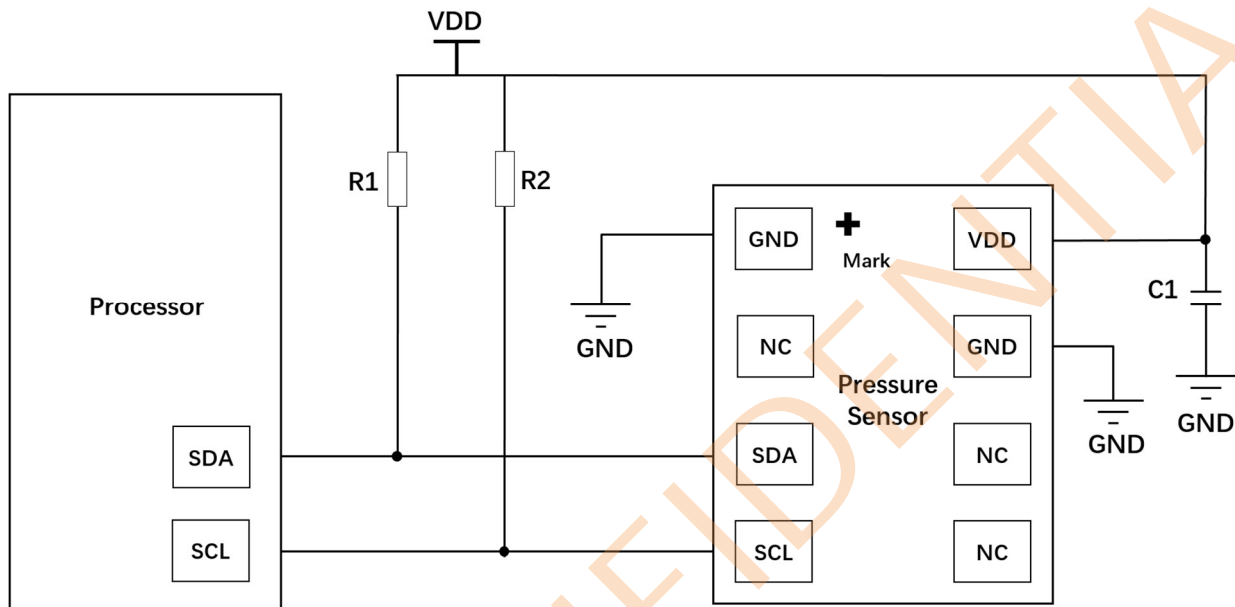

Figure 10: Typical application circuit

Table 23: Component values

Component	Symbol	Typical Value
Pull up resistor	R1,R2	1kΩ
Blocking capacitor	C1	100nF

Note:

- 1) Blocking capacitor must be placed close to the VDD supply pin.



8.2 Recommended settings for different use cases

Table 24 lists relevant use cases with the associated configuration parameters and the expected performance with these settings.

NOTE: current consumption due to the communication interface used is not included.

Table 24: Relevant use-cases with the associated configuration parameters and typical performance

Use cases	Performance	Registers(hex)			Total conversion time (ms)
		MEAS_CFG	OVS_CFG	STBY_CFG	
UAV cruises	0.29 Pa noise 30Hz	0x00	0x23	0x00	31
Height tracking (drones, gaming, AR/VR)	0.2 Pa noise 10Hz	0x08	0x2C	0x00	90
Sports, activity tracking	0.5 Pa noise 10Hz	0x10	0x12	0x05	100

8.3 Oversampling and Precision

Condition: Pconv =1ms, P/T rate=1, one-shot operation.

Table 25: Precision and corresponding settings

Oversampling and Precision				Corresponding Registers (hex)		Total conversion time (ms)
P_OVS	P noise @100kPa (Pa rms)	T_OVS	T noise (mK rms)	MEAS_CFG	OVS_CFG	
1	0.90	1	22.0	0x00	0x00	9
2	0.73	1	22.0	0x00	0x08	10
4	0.53	2	16.1	0x00	0x11	13
8	0.39	4	11.8	0x00	0x1A	19
16	0.29	8	8.6	0x00	0x23	31
32	0.21	16	6.3	0x00	0x2C	55
64	0.15	32	4.6	0x00	0x35	103
128	0.11	64	3.4	0x00	0x3E	199

9. Outline dimensions

The pressure sensor is an 8-Pin LGA package with metal lid. It measures 2.5mm (± 0.1 mm) x 2.0mm (± 0.1 mm) x 0.95mm (± 0.05 mm), undeclared tolerance (± 0.1 mm).

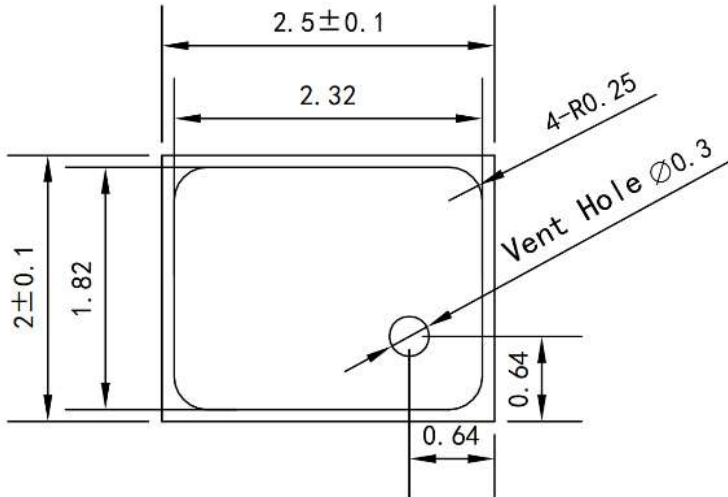

Figure 11: Top view



Figure 12: Side view

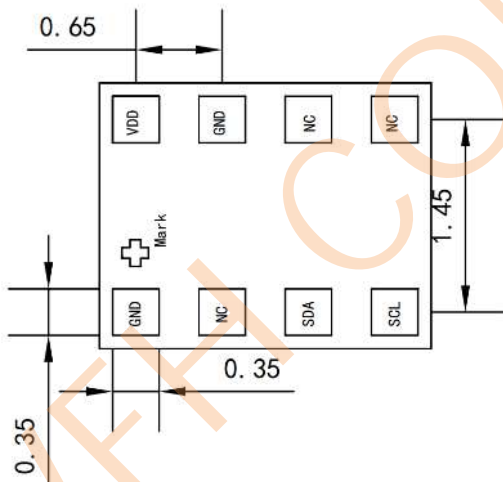

Figure 13: Bottom view

10. Soldering recommendation

Recommended Solder Reflow

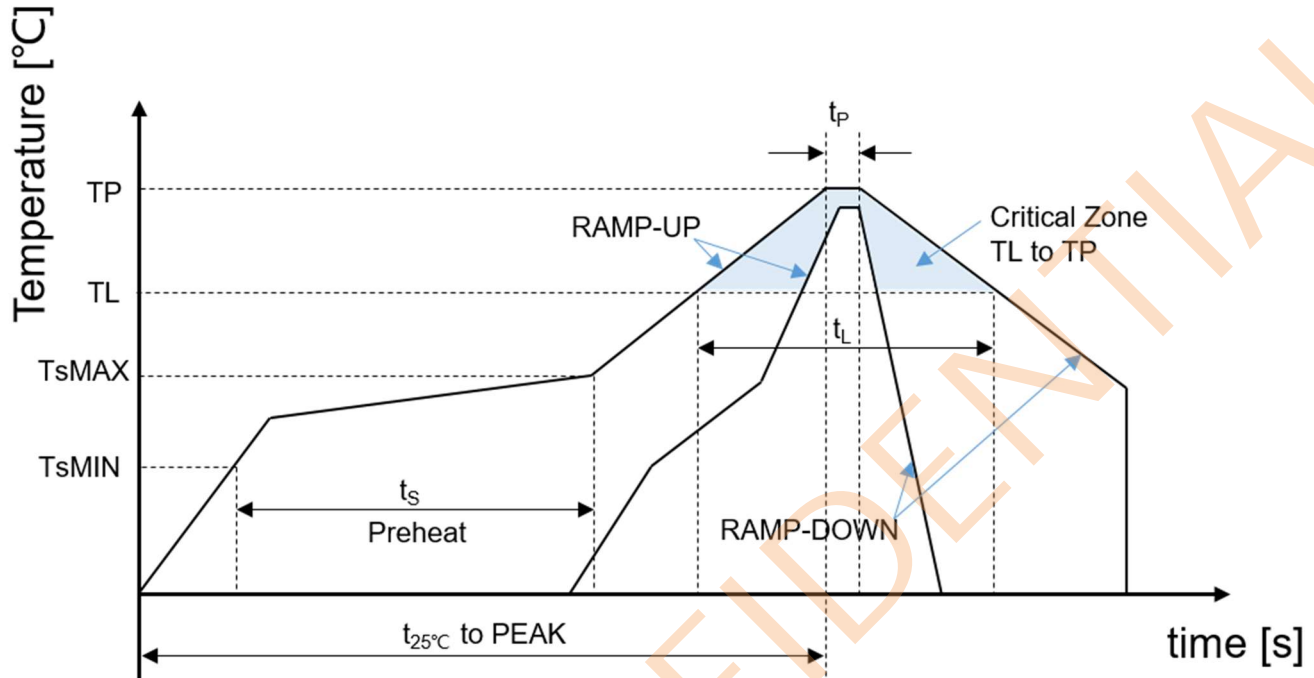

Figure 14: Reflow profile

Table 26: Reflow profile Limits

Profile Feature	Pb-Free Assembly
Average ramp-up rate(TsMAX to TP)	3°C/seconds max.
Preheat	
-Temperature Min.(TsMIN)	150°C
-Temperature Max.(TsMAX)	200°C
-Time(TsMIN to TsMAX)(t_s)	60~80seconds
Time maintained above:	
-Temperature(TL)	217°C
-Time(t_L)	60~150seconds
Peak temperature(TP)	260°C
Time within 5°C of actual peak temperature(t_p)	20~40seconds
Ramp-down rate	4°C/seconds max.
Time 25°C to peak temperature	8 minutes max.

11. Package Specifications

Carrier Tape Information [Unit: mm]

Quantity per reel: 10kpcs.

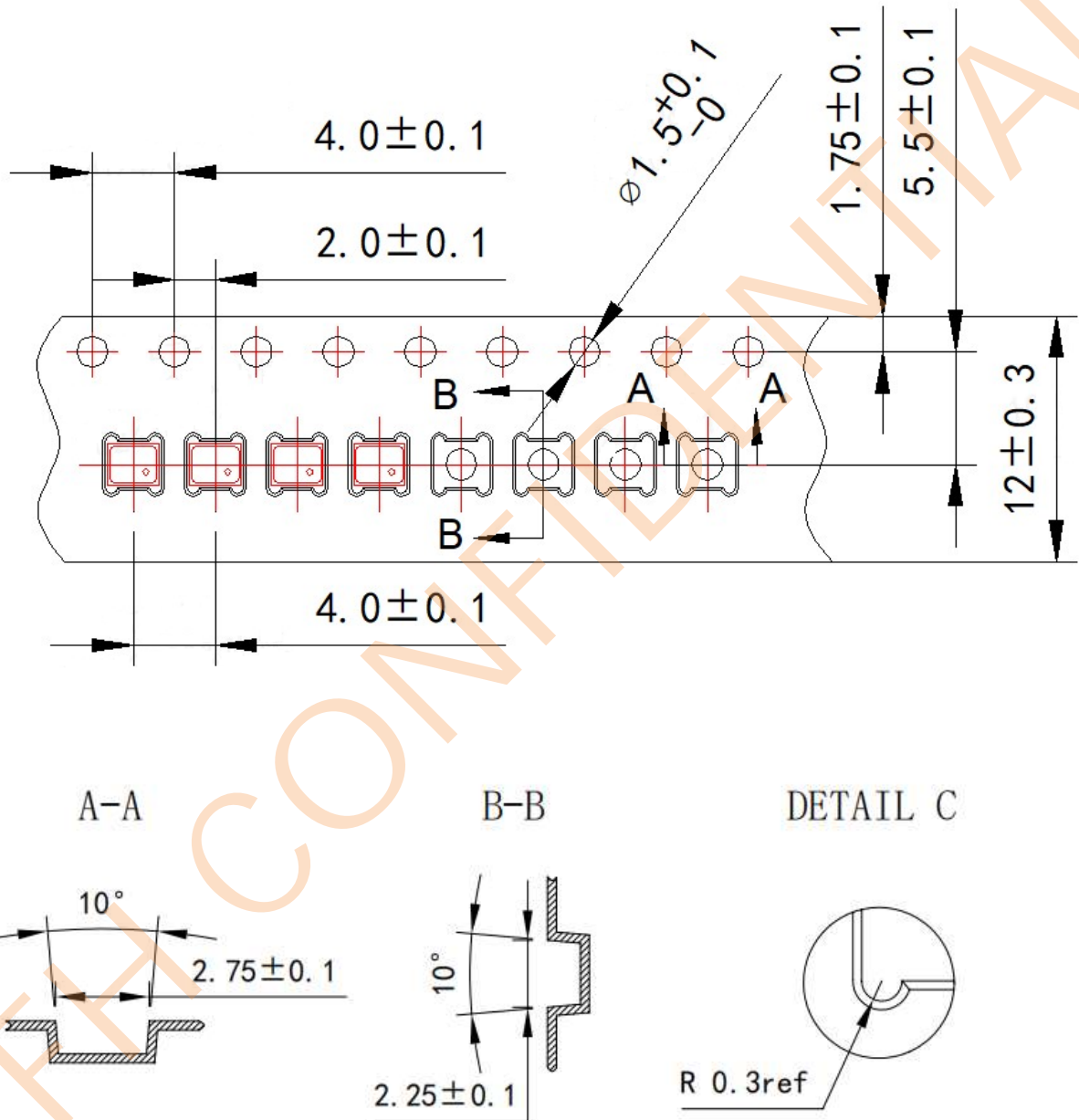

Figure 16: Carrier Tape details

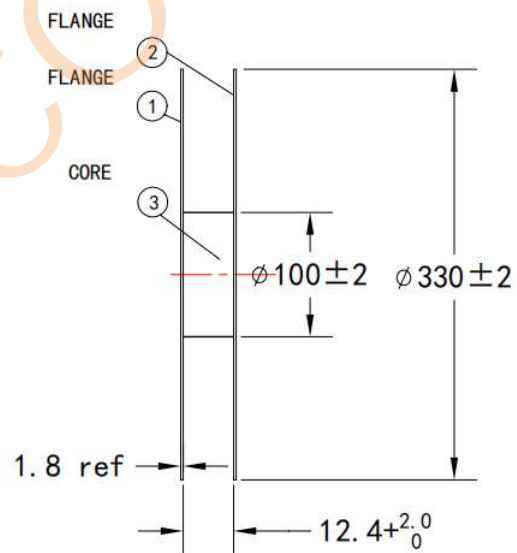
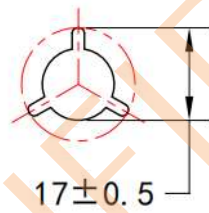
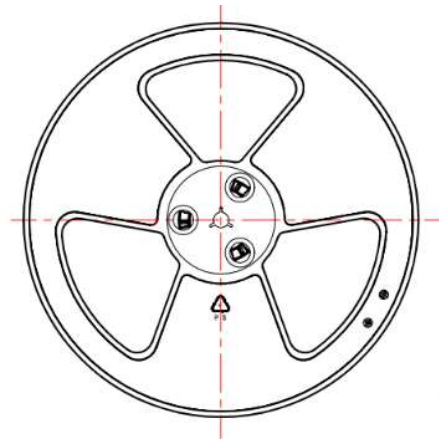

Figure 17: Tape reel